

### SPARE PARTS

No specialist tools are required to repair clamps. Heat may be required to release the bonding compound on some screws.

After repair use STUDLOCK on all screws removed.

Always quote clamp serial number, part description and model when ordering spares.

# CR/CRT

GB

GB Operating instructions

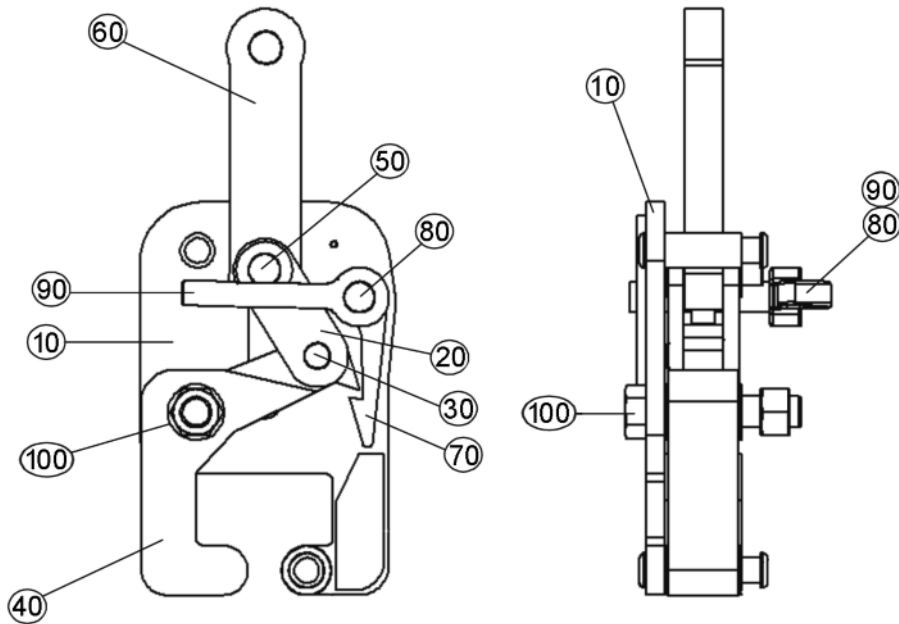

- Rail lifting clamps

## CR/CRT

WLL 1000 - 3000kgs

Item	Description	Qty
10	Shell	1
20	Internal links	2
30	Internal pin	1
40	Jaw	1
50	Hook ring pin	1

Item	Description	Qty
60	Chain link	1
70	Pawl	1
80	Handle shaft	1
90	Handle	1
100	Jaw bolt	1

### Columbus McKinnon Corporation Limited

Knutsford Way,  
Sealand Industrial Estate,  
Chester  
CH1 4NZ  
United Kingdom

Tel: +44 (0) 1244 375375  
Fax: +44 (0) 1244 377403  
Email: sales.uk@cmco.eu  
Web: www.cmco.eu



## INTRODUCTION

Products of Columbus McKinnon Corporation Limited have been built in accordance with the state-of-the-art and generally accepted engineering standards. Nonetheless, incorrect handling when using the products may cause dangers to life and limb of the user or third parties and/or damage to the hoist or other property.

The operating company is responsible for the proper and professional instruction of the operating personnel. For this purpose, all operators must read these operating instructions carefully prior to the initial operation.

These operating instructions are intended to acquaint the user with the product and enable him to use it to the full extent of its intended capabilities. The operating instructions contain important information on how to operate the product in a safe, correct and economic way. Acting in accordance with these instructions helps to avoid dangers, reduce repair costs and downtimes and to increase the reliability and lifetime of the product. The operating instructions must always be available at the place where the product is operated. Apart from the operating instructions and the accident prevention act valid for the respective country and area where the product is used, the commonly accepted regulations for safe and professional work must also be adhered to.

The personnel responsible for operation, maintenance or repair of the product must read, understand and follow these operating instructions.

The indicated protective measures will only provide the necessary safety, if the product is operated correctly and installed and/or maintained according to the instructions. The operating company is committed to ensure safe and trouble-free operation of the product.

## TYPE OF RAIL

The Camlok CR series of rail lifting clamps can be used to lift the following types of headed rail sections:

- 85lb Bull head rail
- 95lb Bull head rail
- 98lb Flat bottom rail
- 109lb Flat bottom rail
- 110A Flat bottom rail
- 113lb Flat bottom rail
- 113A Flat bottom rail
- UIC54 Flat bottom rail
- UIC 60 Flat bottom rail
- 100lb Conductor rail
- 106lb Conductor rail
- 150lb Conductor rail

The CRT rail lifting clamps are bespoke designed to suit one specific type of grooved tram rail.

## FITTING

- Take the weight of the clamp.
- The lifting sling must be slack.
- Open the clamp jaw by operating the release handle and pushing down the clamp shackle link.
- The clamp will remain in this open position after releasing the handle.
- Lower the clamp onto the rail, guiding it by hand to ensure that the roller jaw is under the rail head.
- Lock the clamp onto the rail with an upward pull on the shackle link.
- Check correct fitting and position before lifting.

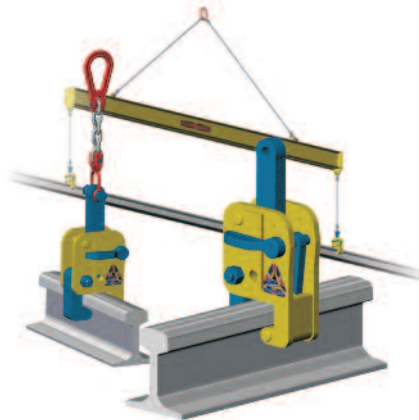

## LIFTING

- The operator should gently lift the clamp so that the rail is just clear of the ground, then check that all items are functioning correctly and that the rail is completely clear of any obstruction.

- Lift slowly and smoothly at all times.
- Minimise side loading.
- Take precautions to stop the load from swinging.
- Place loads down gently.

## TRANSPORTING

- Take precautions when transporting loads that the rail will not collide with any objects.
- Minimise load swing.
- Minimise the danger area by moving rails as close to the ground as possible.

## RELEASE

- Lower the rail into the required position and ensure that it is completely stable before attempting to release the clamp.
- Lower off a little more to allow the safety chain to become sufficiently slack to enable the clamp to fully release.
- Press the release handle whilst pushing down the clamp shackle link to open the clamp jaw and then lift the clamp.
- Ensure that the fixed jaw does not become trapped under the rail head, otherwise the clamp will again lock closed onto the rail.
- The clamp is now ready for the next lift.

## GENERAL

Model	WLL kgs	Weight kgs
CR1000	1000	12.5
CR2000	2000	12.5
CR3000	3000	13
CRT1000	1000	13

- Rail less than 6mtrs long may be lifted by one clamp.
- Rails between 6mtrs and 18mtrs must be lifted by two clamps and a lifting beam.
- Do not lift rails longer than 18mtrs with only 2 clamps.
- Always check the operation of your Camlok lifting clamp before use.
- Never use a worn or damaged lifting clamp.
- Never lift more than one rail at a time.
- Never exceed the maximum working load limit.
- Never fast lower always gently lift and lower.
- Never force the locking lever.

- Never stand under a suspended load and if guiding a load by hand always place the palm of the hand on top of the load.
- Never grip the load with fingers on the underside.
- Always stand clear when lifting or lowering.
- Always keep a record of inspections and repairs.



## TESTING

All Camlok lifting clamps are tested before sale to a proof load of twice the working load limit. Any clamp that has been repaired must be tested to this load before re-entering service.

## CARE AND MAINTENANCE

- De-grease clamps regularly.
- Remove all grit, dirt and mud.
- Lubricate all moving parts with a soft grease.
- Inspect every 1-4 weeks, depending on use.
- Check for wear in the jaw, hookring, and chain.
- Check for distortion in the shell plates, jaw bolt, internal links and the spring.
- Check any welds for cracks.
- Check for smooth operation.
- Check fasteners for integrity and tightness.

*All fasteners fitted to Camlok lifting clamps are retained with Loctite 270 Thread Locking compound. DO NOT use any other grade.*

**Further information and operating instructions are to be found at [www.camlok.co.uk](http://www.camlok.co.uk)**